

SMART DIFFERENTIAL PRESSURE TRANSMITTER

HART® Communication, Push Button Configuration, Rangeability (Up to 25:1)

CALIBRATION SERVICES AVAILABLE

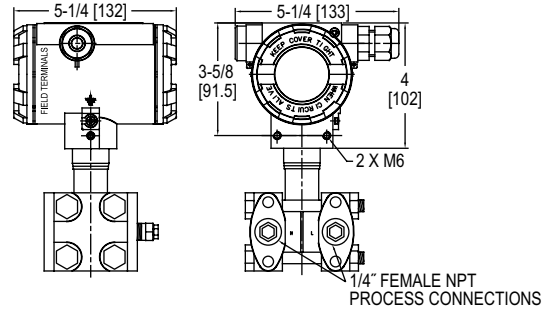

The Series 3500 Smart Differential Pressure Transmitter is a microprocessor-based high performance transmitter, which has flexible pressure calibration, push button configuration, and is programmable using HART® Communication. The Series 3500 is capable of being configured for differential pressure or level applications with the zero and span buttons. A field calibrator is not required for configuration. The transmitter software compensates for thermal effects, improving performance. EEPROM stores configuration settings and stores sensor correction coefficients in the event of shutdowns or power loss. The Series 3500 can be configured to be ATEX or IECEx approved for use in hazardous (classified) locations. The rangeability allows the smart transmitter to be configured to fit any application.

BENEFITS/FEATURES

- High accuracy ($\pm 0.075\%$ FS)
- Rangeability (up to 25:1)
- Configurable using zero/span buttons (no calibrator required)
- Fail-mode process function
- Automatic ambient temperature compensation

APPLICATIONS

- Flow measurement
- Level monitoring
- Filter or pump differential pressure
- Critical process monitoring

MODEL CHART	
Model	Range
3500-AL-02-NF-2	-10 to 10 in w.c.
3500-AL-04-NF-2	0 to 30 in w.c.
3500-AL-08-NF-2	0 to 100 in w.c.
3500-AL-10-NF-2	-200 to 200 in w.c.
3500-AL-15-NF-2	0 to 1000 in w.c.
3500-AL-20-NF-2	0 to 15 psi
3500-AL-25-NF-2	0 to 100 psi

Note: Bar ranges are also available.

SPECIFICATIONS

Service: Compatible gases, steam, liquids or vapors.
Wetted Materials: 316L SS and FPM; with diaphragm seal: 316L SS.
Accuracy: $\pm 0.075\%$ FS (@ 20°C).
Rangeability: Up to 25:1 turn down.
Stability: $\leq 0.075\%$ FSO/3 years.
Temperature Limits: Ambient: -40 to 185°F (-40 to 85°C); Process with -DS: -40 to 400°F (-40 to 204°C).
Thermal Effect: $< \pm 0.05\%$ span/10°C.
Power Requirements: 10-55 VDC.
Output Signal: 4-20 mA.
Response Time: 16 to 480 ms (programmable).
Damping Time: 0 to 60 s.
MTBF (Mean Time Between Failure): 124 years.
MTTF (Mean Time To Failure): MTBF minus 8 h.

Electrical Connection: Packing gland M20x1.5, two 1/2" female NPT conduit, screw terminal.
Process Connections: 1/4" female NPT.
Enclosure Rating: NEMA 4X IP66/IP67.
Compliance: CE: -IS, -FP suffix: ATEX Compliant **CE** 0518 II 2G **Ex** ia/db IIC T6/T5 Gb Ta<80°C, T5 / II 2D Ex ia/tb IIIC T85°C/T100°C Db, Type Certificate No. KDB 17ATEX0056X. ATEX Standards: EN 60079-0:2012+A11:2013, EN 60079-1:2014, EN 60079-11:2012, EN 60079-26:2015, EN 60079-31:2014 IECEx Compliant: Ex ia/db IIC T6/T5 Gb / Ex ia/tb IIIC T85°C/T100°C Db, Certificate of Conformity IECEx KDB 17.0008X. IECEx Standards: IEC 60079-0:2011, IEC 60079-1:2014-06, IEC 60079-11:2011, IEC 60079-26:2006, IEC 60079-31:2013.

MODEL CHART												
Example	3500	-AL	-01	-DS	-1	-SPRB	A	0	-1	-1	-NIST	3500-AL-01-DS-1-SPRBA0-1-1-NIST
Series	3500											Smart differential pressure smart transmitter
Housing		AL AS										Aluminum housing SS housing
Range			02 04 08 10 15 20 25 38 40 50 60									-10 to 10 in w.c. 0 to 30 in w.c. 0 to 100 in w.c. -200 to 200 in w.c. 0 to 1000 in w.c. 0 to 15 psi 0 to 100 psi 0 to 230 psi 0 to 1000 psi -2.5 to 2.5 in w.c. -1.5 to 1.5 psi
Process Connections				NF DS								1/4" female NPT adaptor Diaphragm seal selection
Electrical Connections					1 2							Packing gland M20x1.5 Thread 1/2" female NPT
Diaphragm Seal Type						SPDH SPRB SPRH STDH STRB STRH						S-P flush diaphragm seal direct mount high side S-PK flush diaphragm seal capillary type both sides S-PK flush diaphragm seal capillary type high side S-T extended diaphragm seal direct mount high side S-TK extended diaphragm seal capillary type both sides S-TK extended diaphragm seal capillary type high side
Mounting Flange							A B C D					2" ANSI 2" DN50 3" ANSI 3" DN80
Extension Length								0 2 4 6				No extension, flush mount 2" (50 mm) 4" (100 mm) 6" (150 mm)
Capillary Length High Side									#			High side capillary length, 1 to 20 ft (increments of 1)
Capillary Length Low Side										#		Low side capillary length, 1 to 20 ft (increments of 1)
Options												FP ATEX/IECEx flameproof GB 2" galvanized steel mounting bracket IS ATEX/IECEx intrinsically safe MT SS tag plate mounted on wire NIST NIST traceable calibration certificate SB 2" SS mounting bracket ST SS plate riveted to the housing

ACCESSORIES			
Model	Description	Model	Description
A-630	SS angle type bracket with SS bolts	BBV-0N	2-valve block manifold
A-631	SS flat type bracket with SS bolts	DevCom2000	HART® communication protocol software

HART® is a registered trademark of Fieldcomm Group, Inc.

PRESSURE
Differential Pressure Transmitters,
Liquid & Gas